

HAFCO METALMASTER

HORIZONTAL BAND SAW OPERATION MANUAL



Model
EB-260V
Order Code B062V

Edition No :EBS-001

Date of Issue :04/2019

www.machineryhouse.com.au



OPERATION MANUAL

MACHINE DETAILS

MACHINE	<input type="text" value="METAL CUTTING BAND SAW"/>
MODEL NO.	<input type="text" value="EB-260V"/>
SERIAL NO.	<input type="text"/>
DATE OF .	<input type="text"/>

Distributed by



www.machineryhouse.com.au

www.machineryhouse.co.nz

NOTE:

This manual is only for your reference. Owing to the continuous improvement of the HAFCO machines, changes may be made at any time without obligation or notice. Please ensure the local voltage is the same as listed on the specification plate before operating this electric machine.



NOTE:

In order to see the type and model of the machine, please see the specification plate. Usually found on the back of the machine. See example (Fig.1)

PRODUCT SPECIFICATION

MODEL:

CAPACITY:

SER. NO.:

MFG DATE:

WEIGHT:

VOLTS:

MOTOR Kw:

www.machineryhouse.com.au
Made in China

Fig.1



OPERATION MANUAL

CONTENTS:

1. GENERAL MACHINE INFORMATION	
1.1 Specifications.....	4
1.2 Standard Equipment.....	4
1.3 Identification.....	5
2. IMPORTANT INFORMATION	
2.1 General Safety Requirements.....	6
2.2 Safety Features For Band Saws.....	8
2.3 Lifting Instructions.....	9
2.4 Machine Stand Assembly.....	9
3. SETUP	
3.1 Site Preparation.....	10
3.2 Clean Up.....	10
3.3 Machine Mounting Options.....	10
3.4 Machine Leveling.....	11
3.5 Electrical Installation.....	11
3.6 Full Load Current Rating.....	12
4. OPERATION	
4.1 Controls.....	12
4.2 Coolant System.....	14
4.3 Blade Guides.....	15
4.4 Setting The Down Feed.....	15
4.5 Setting The Cutting Angle.....	16
4.6 Adjusting The Speed Of The Saw Blade.....	17
4.7 Bundle Cutting.....	17
4.8 Blade Selection.....	18
5. MAINTENANCE	
5.1 Schedule.....	19
5.2 Changing The Blade.....	19
5.3 Changing The Coolant.....	20
5.4 Blade Guide Adjustment.....	21
5.5 Adjusting Feed Stops.....	22
5.6 Adjusting The Auto Feed Stop.....	22
5.7 Adjusting The Head Swivel Stops.....	22
5.8 Trouble Shooting.....	24
SPARE PARTS.....	25
Risk Assessment.....	30

OPERATION MANUAL

1.1. SPECIFICATIONS

Order Code	B062V
Model	EB-260
Operation Type	Swivel Head
Round @ 90° (mm)	225
Round @ 45° (mm)	150
Round @ 60° (mm)	100
Square @ 90° (mm)	180
Square @ 45° (mm)	140
Square @ 60° (mm)	100
Rectangle (W x H) @ 90° (mm)	225 x 180
Rectangle (W x H) @ 45° (mm)	140 x 140
Rectangle (W x H) @ 60° (mm)	100 x 100
Coolant System	Yes
Table Working Height (mm)	950
Cutting Head Beam Type	Manual
Cutting Head Beam Return	Manual Return
Cutting Head Down Feed Control:	Adjustable Hydraulic
Vice Clamping Fixture:	Manual Quick Action
Bundle Cutting Fixture:	~
Blade Steps / Speeds (m/min):	Variable 20-90
Blade Size (L x W x T) (mm):	2480 x 27 x 0.9
Motor Power (kW / hp):	1.5/2
Voltage / Amperage (V / amp):	240/10
Nett Weight (kg):	200

1.2. STANDARD EQUIPMENT

- Machine stand and drip tray.
- Blade cleaning brush
- Ball bearing blade guides



OPERATION MANUAL

1.3. IDENTIFICATION

Become familiar with the names and locations of the controls and features shown below to better understand the instructions in this manual.

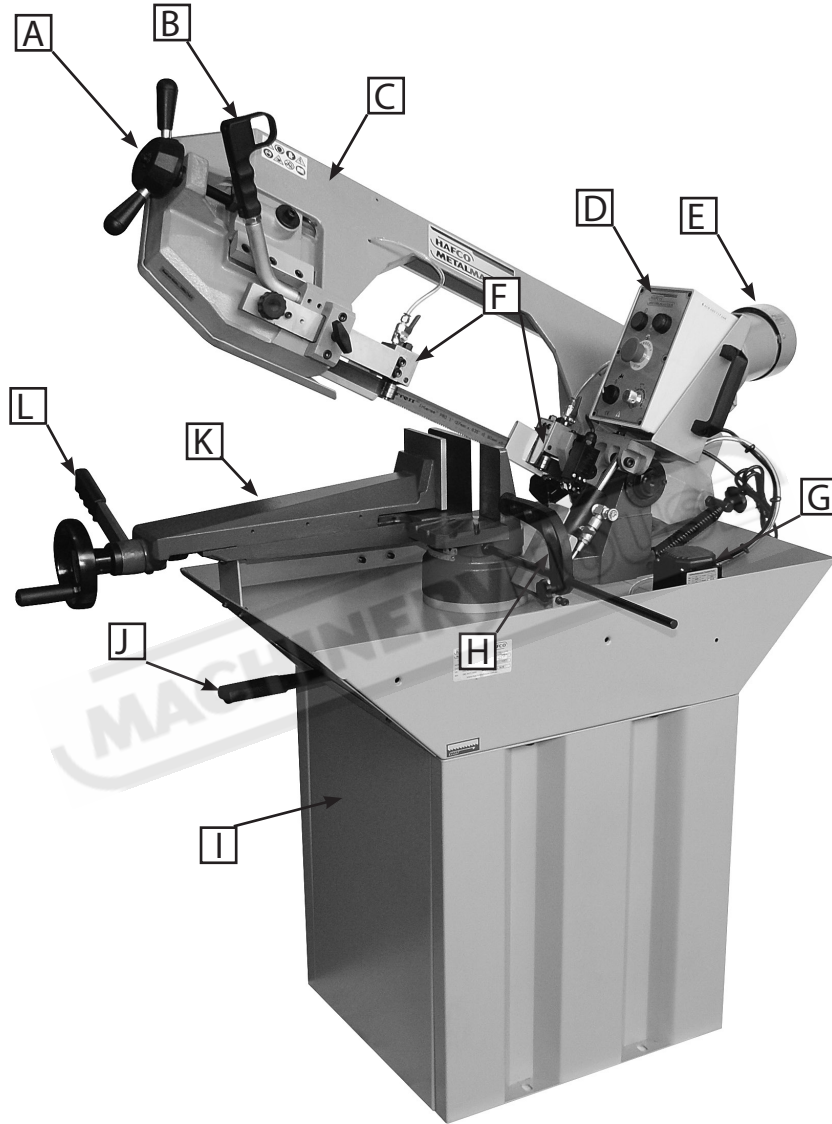

A	Blade Tension Handle	E	Motor	I	Stand
B	Lifting Handle	F	Ball Bearing Guide	J	Head Lock
C	Saw Bow	G	Coolant Pump	K	Vice
D	Control Panel	H	Length Stop	L	Quick Action Handle

2. IMPORTANT INFORMATION

2.1 GENERAL SAFETY REQUIREMENTS

DO NOT use this machine unless you have read this manual or have been instructed in the use of this machine in its safe use and operation



WARNING

This manual provides safety instructions on the proper setup, operation, maintenance, and service of this machine. Save this manual, refer to it often, and use it to instruct other operators. Failure to read, understand and follow the instructions in this manual may result in fire or serious personal injury—including amputation, electrocution, or death.

The owner of this machine is solely responsible for its safe use. This responsibility includes, but is not limited to proper installation in a safe environment, personnel training and authorization to use, proper inspection and maintenance, manual availability and comprehension, of the application of the safety devices, integrity, and the use of personal protective equipment.

The manufacturer will not be held liable for injury or property damage from negligence, improper training, machine modifications or misuse.



Safety glasses must be worn at all times in work areas. Earmuffs should be worn if the work area is noisy.



Sturdy footwear must be worn at all times in work areas.



Gloves should NOT be worn when using this machine. They should be used when handling the work piece



Long and loose hair must be contained with a net or under a hat

OWNER'S MANUAL. Read and understand this owner's manual before using the machine.

DISCONNECT POWER FIRST. If using power, always disconnect the machine from power supply before making adjustments, or servicing the machine. This prevents any risk of injury from unintended startup or contact with live electrical equipment

TRAINED OPERATORS ONLY. Operators that have not been trained have a higher risk of being seriously injured. Only allow trained or supervised people to use this machine. When the machine is not being used, disconnect the power, to the machine to prevent unauthorized use—especially around children. Make the workshop safe.

2.1 GENERAL SAFETY REQUIREMENTS Cont.

WEARING PROPER APPAREL. Do not wear clothing, apparel or jewelry that can become entangled in moving parts. Always tie back or cover long hair. Wear non-slip footwear to avoid accidental slips, which could cause loss of operating control.

HEARING PROTECTION. Always wear hearing protection when operating or observing loud machinery. Extended exposure to this noise without hearing protection can cause permanent hearing loss.

REMOVE ADJUSTING TOOLS. Tools left on machinery can become dangerous projectiles upon startup. Never leave hex keys, wrenches, or any other tools on the machine. Always verify removal before starting!

USE CORRECT TOOL FOR THE JOB. Only use this tool for its intended purpose. Do not force the machine or its attachments to do a job for which they were not designed. Never make unapproved modifications. Modifying the machine or using it differently than intended may result in malfunction or mechanical failure that can lead to personal injury or death!

AWKWARD POSITIONS. Keep proper footing and balance at all times when operating machine. Do not overreach! Avoid awkward hand positions that make operating control difficult. This could increase the risk of accidental injury

GUARDS & COVERS. Guards and covers reduce accidental contact with moving parts or flying debris. Make sure they are properly installed, undamaged, and working correctly.

FORCING MACHINERY. Do not force the machine. It will do the job safer and better at the rate for which it was designed.

NEVER STAND ON MACHINE. Serious injury may occur if the machine is tipped or if the cutting tool is unintentionally contacted

STABLE MACHINE. Unexpected movement during operation greatly increases risk of injury or loss of control. Before starting, verify the machine is stable and if using a mobile base it is locked in position.

UNATTENDED OPERATION. To reduce the risk of accidental injury, turn the machine OFF and ensure all moving parts have completely stopped before walking away. Never leave the machine running while unattended.

MAINTAIN WITH CARE. Follow all maintenance instructions and lubrication schedules to keep the machine in good working condition. A machine that is improperly maintained could malfunction, leading to serious personal injury or death.

CHECK DAMAGED PARTS. Regularly inspect the machine for any condition that may affect the safe operation. Immediately repair or replace damaged or parts that are incorrectly fitted before operating.

CHILDREN & BYSTANDERS. Keep children and bystanders at a safe distance from the work area. Stop using machine if they become a distraction.

BLADE CONDITION. Do not operate with dull, cracked or badly worn blades. Inspect the blades for broken teeth before each use.

OPERATION MANUAL

2.2 SAFETY FEATURES FOR BAND SAWS

DO NOT use this machine unless you have been instructed in its safe use and the operator has read and understands the instructions in this manual



Safety glasses must be worn at all times in work areas.



Long and loose hair must be contained.



Hearing protection must be worn around noisy machines



Sturdy footwear must be worn at all times in work areas.



Close fitting/protective clothing must be worn.



Rings and jewelry must not be worn

PRE-OPERATIONAL SAFETY CHECKS

- Locate and ensure you are familiar with all machine operations and controls
- Ensure all guards are fitted, secure and functional. Do not operate if guards are missing or faulty.
- Check workspaces and walkways to ensure no slip/trip hazards are present.
- Ensure the hydraulic clamping mechanism functions correctly.
- Check that the blade is in good condition.
- Ensure the blade's speed, tension and tracking are properly adjusted.
- Check coolant delivery system to allow for sufficient flow of coolant.

OPERATIONAL SAFETY CHECKS

- Lift the head of the unit up and lock it in the upward position.
- Set the angle of the vice or check it to ensure its squareness.
- Clamp workpiece firmly into the vice. Long material must be supported.
- Adjust blade guards to cover unused portion of blade.
- Ensure hands are away from the blade, and then turn the machine on.
- Allow the upper head assembly to come down slowly until the teeth are cutting the material.
- Keep hands away from the blade and cutting area.
- Turn off the machine and bring it to a complete standstill if the blade is to be lifted out of an uncompleted or jammed cut.
- Stop the saw immediately if the blade develops a 'click', and check for a broken tooth
- Ensure the saw bow is locked in the upward position before removing workpiece from vice

ENDING OPERATIONS AND CLEANING UP

- Switch off the machine when work completed.
- Reset all guards to a fully closed position.
- Before removing scrap pieces from the vice area or making adjustments, Stop the machine and bring it to a complete standstill.
- Leave the machine in a safe, clean and tidy state

DON'T

- Do not use faulty equipment. Immediately report suspect machinery.
- Do not push down on the cutting head while it is cutting.
- Never leave the machine running unattended.

2.3 LIFTING INSTRUCTIONS

On the day that the machine arrives, make sure that a crane with sufficient capacity is available to unload the machine from the vehicle. Ensure access to the chosen site is clear and that doors and ceilings are sufficiently high and wide enough to receive the machine.

To handle the machine, the slings should be positioned so the machine is level when lifted. When using slings please take note of the sling angle and the loads that apply.

LIFTING POINTS

Use only the 4 eye bolts supplied with the machine to attach the slings. When lifting the machine only certified lifting slings should be used. Ensure that when lifting, the machine does not tip over. Check that the lifting slings do not interfere with the hydraulic pipes or electrical conduits. Failure to follow these instructions could cause damage to the machine.

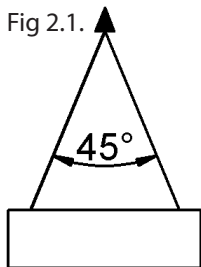

When the slings are at a 45° angle then each sling is carrying the equivalent of 50% of load weight. (Fig.2.1).

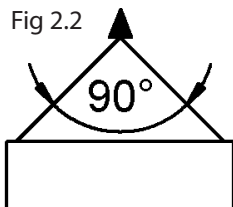

When the slings are at a 90° angle then each sling will have a weight equal to 75% of the load on each sling.(Fig 2.2)

Note! The manufacturer recommends not to exceed 90° angle

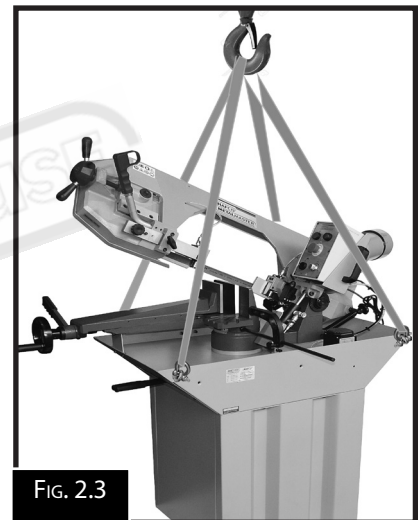

FIG. 2.3

2.4 MACHINE STAND ASSEMBLY

To assemble the stand, find a flat even space with plenty of room to layout the side panels.

- Fit the side panels of the machine stand as shown in the diagram Fig. 2.4.
- Place the metal belt saw on the machine stand.
- Bolt the metal belt saw to the machine stand.
- Bolt the drip pan to the machine stand

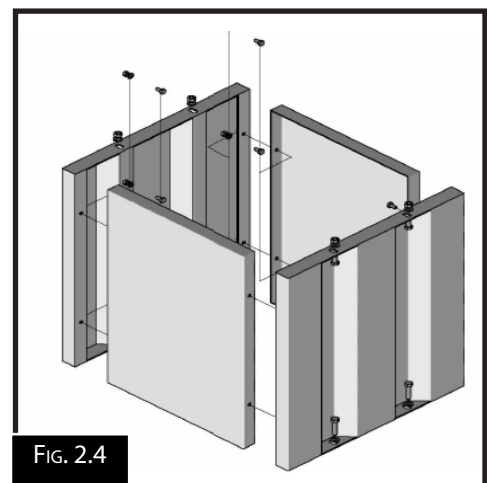

FIG. 2.4

3. SETUP

3.1 SITE PREPARATION

When selecting the site for the machine, consider the largest size of workpiece that will be processed through the machine and provide enough space around the machine for operating the machine safely. Consideration should be given to the installation of auxiliary equipment. Leave enough space around the machine to open or remove doors/covers as required for the maintenance and service as described in this manual.

It is recommended that the machine is anchored to the floor to prevent tipping or shifting. It also reduces vibration that may occur during operation. The machine should be mounted on a reinforced concrete floor with a minimum of 150mm thickness. The floor must be able to support the weight of the machine any workpiece that is to be worked.

3.2 CLEAN - UP

The unpainted surfaces of the machine have been coated with a waxy oil to protect them from corrosion during shipment. Remove the protective coating with a solvent cleaner or a citrus based degreaser.

Optimum performance from your machine will be achieved when you clean all moving parts or sliding contact surfaces that are coated with rust prevented products.

Hafco advise to avoid chlorine based solvents, such as acetone or brake parts cleaner, as they will damage painted surfaces and strip metal should they come in contact. Always follow the manufacturer's instructions when using any type of cleaning product.

3.3 MACHINE MOUNTING OPTIONS

Although it is not required Hafco recommends that you secure your machine to the floor. Masonry anchors with bolts are the best way to anchor machinery, because the anchors sit flush with the floor surface, making it easy to unbolt and move the machine later, if needed. (Fig. 3.1) Other methods of mounting is the use of machine mounts which also help with the levelling of the machine and isolating vibration. (Fig.3.2)

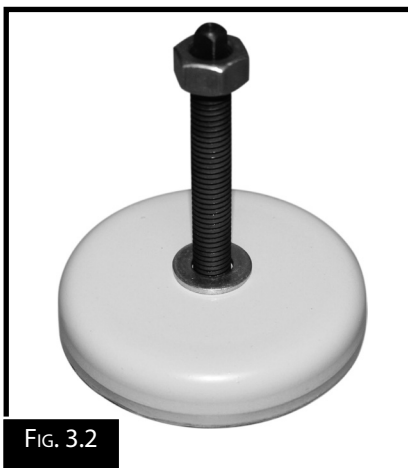
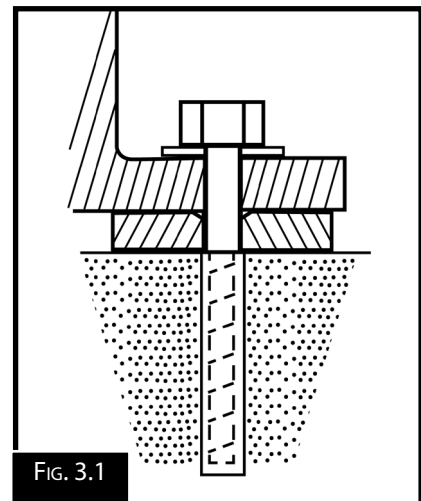

3.4 MACHINE LEVELING

To set your machine up so that it operates to optimum performance, apply the following procedure

After your machine has been anchored to a concrete slab floor, it then needs to be leveled. Loosen the hold down bolts and place a level on the surface of the working table. Metal shims need to be placed under corner of the base of the machine until level. Once level then tighten the hold down bolts. (Fig. 3.3).

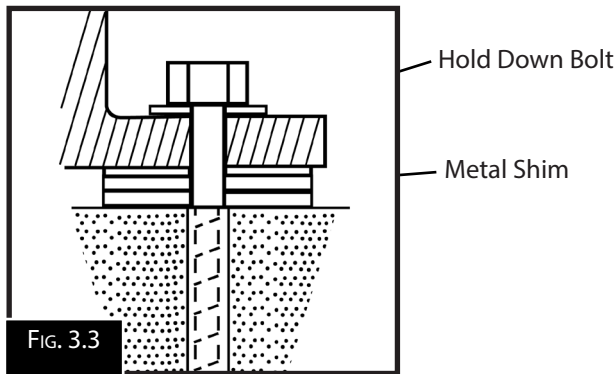

The machine must not rest on supports other than those defined in Fig. 3.1

3.5 ELECTRICAL INSTALLATION

Place the machine near an existing power source. Make sure all power cords are protected from traffic, material handling, moisture, chemicals, or other hazards. Make sure there is access to a means of disconnecting the power source. The electrical circuit must meet the requirements for 240V.

NOTE : The use of an extension cord is not recommended as it may decrease the life of electrical components on your machine.

ELECTRICAL REQUIREMENTS

- Nominal Voltage..... 240V**
- Cycle..... 50 Hz**
- Phase..... Single Phase**
- Power Supply Circuit.....10 Amps**
- Full Load Current..... 6.0 Amps**

(Full load current rating is also on the specification plate on the motor.)

3.6 FULL-LOAD CURRENT RATING

The full-load current rating is the amperage a machine draws when running at 100% of the output power. Where machines have more than one motor, the full load current is the amperage drawn by the largest motor or a total of all the motors and electrical devices that might operate at one time during normal operations.

Full-Load Current Rating for these machine at 240V is 6.0 Amps

It should be noted that the full-load current is not the maximum amount of amps that the machine will draw. If the machine is overloaded, it will draw additional amps beyond the full-load rating and if the machine is overloaded for a long period of time, damage, overheating, or fire may be caused to the motor and circuitry.

This is especially true if connected to an undersized circuit or a long extension lead. To reduce the risk of these hazards, avoid overloading the machine during operation and make sure it is connected to a power supply circuit that meets the requirements.



4. OPERATION

4.1 CONTROLS (FIG.4.1)

- A. OFF Button.** When pressed the motor and blade are stopped.
- B. ON Button.** When pressed energizes the electrical system ready to operate when the trigger is depressed.
- C. Emergency Stop.** When pressed all electrical operating items will stop. To allow the machine to restart the red button needs to be twisted to allow the button to pop up. Now the start button will operate.
- D. Coolant Switch.** Switches on or off the coolant pump.
- E. Speed Control.** When turned adjust the speed of the blade in mtrs/min

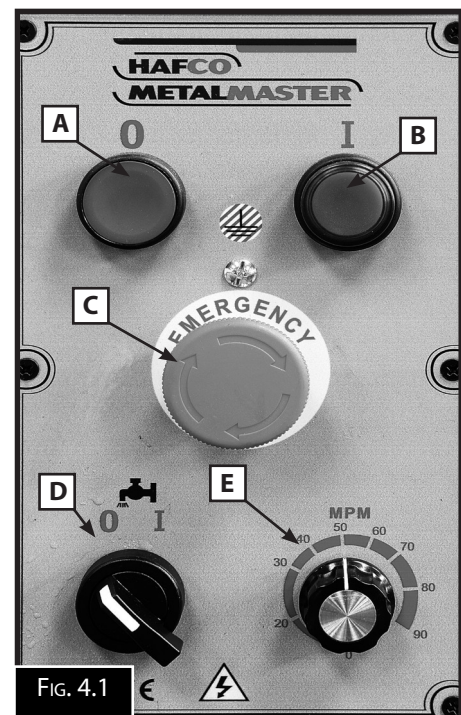

FIG. 4.1

LIFT-UP & SWIVEL HANDLES

The machine is fitted with two handles. One to help when lifting the head and then both handles are used to help control the head when it needs to be swiveled. (Fig. 4.2)



FIG. 4.2

QUICK ACTION VISE

The band saw is fitted with a quick action vise that allows for the quick tightening or releasing of material in the vise. The quick action has a limited stroke so the hand wheel is required to move the vise jaws closer together.

(Fig. 4.3)

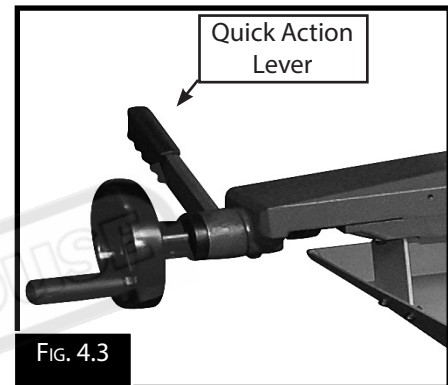

FIG. 4.3

TENSIONING THE SAW BLADE

Check the tension of the saw blade. The tension in the saw blade is correct if the middle of the blade between the supports, can be pushed down no more than 3 mm with a force of approximately 50 N.

The tension of the saw blade can be adjusted by means of the hand wheel. (Fig.4.4)



FIG.4.4

LENGTH STOP

The machine is fitted with an adjustable length stop. (Fig.4.5)

To install the length stop

1. Screw the threaded rod into the base of the machine and tighten the lock nut.
2. Slide the length stop onto the rod
3. Measure the distance from the blade to the face of the length stop and move the length stop in or out until the correct measurement is achieved.
4. Tighten the length stop on the rod.

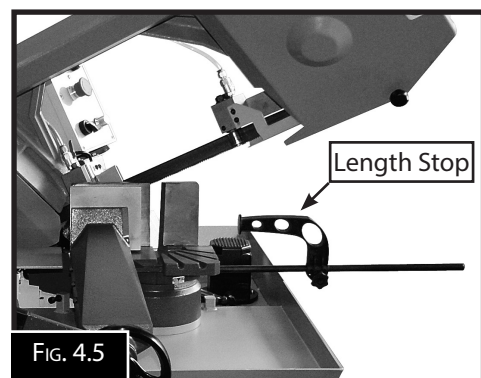

FIG. 4.5

OPERATION MANUAL

4.2 COOLANT SYSTEM

The sawing movement produces high temperatures at the edge of the blade due to the friction generated. The blade must therefore be cooled during operation. Using a suitable lubricant or cooling agent leads to better results and longer saw blade life. (Fig. 4.6)

The coolant is delivered through two taps situated on the blade guide assemble.

To start the coolant turn the switch on the control panel (D in Fig.4.1) and press and hold the trigger switch, then adjust the taps. (Fig.4.7 & 4.8) Too much flow at the nozzle will make a mess of the work area and cause it to become unsafe, but too little will cause the blade to over-heat, causing the blade teeth to load up and break.

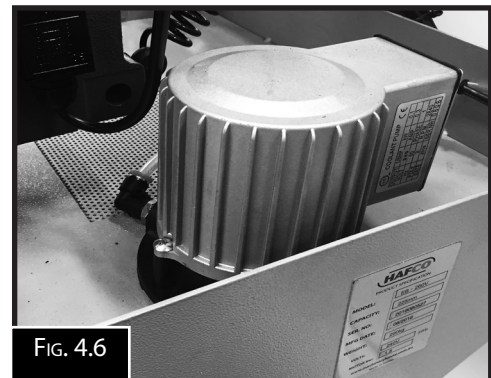
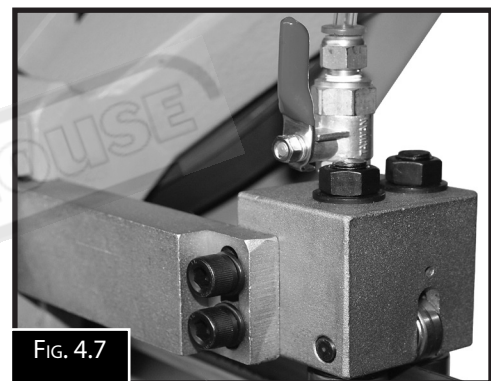

FIG. 4.6

FIG. 4.8

FIG. 4.7

COOLANT SELECTION

Soluble Oils

The most common of all water-soluble cutting fluids, soluble oils (also known as emulsifiable cutting fluids) are typically 50 percent oil before dilution. When mixed with water, they form a milky emulsion that is an excellent choice for general purpose cutting. They are, however, prone to “Monday morning stink”—a foul-smelling odor from microbiological growth of fungus and bacteria that can grow in your coolant sump if not properly maintained.

Synthetic Fluids

As you can probably guess from the name, synthetics contain no oil, using various polymers and chemical compounds to replicate oil’s natural lubricity. They reject tramp oil, so they tend to be the cleanest of all cutting fluids, but are often the least lubricious. They are commonly used in grinding applications, but proponents suggest that synthetics can be tailored to virtually any metalworking operation, especially metal cutting band saws.

HAFCO recommend that **Synthetic** cutting oil be used available in two sizes.

5 Ltr Order Code S090

20 ltr Order Code S091

4.3 BLADE GUIDES

The upper blade guide should be as close to the workpiece as possible. This helps ensure straight cuts by keeping the blade from twisting or drifting off the cut line. (Fig.4.9)

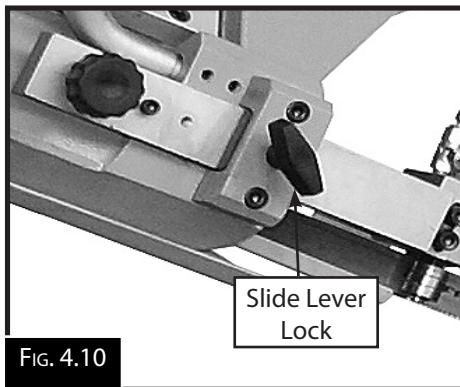

FIG. 4.10

Adjust the upper blade guide by loosening the slide lever lock as in Fig.4.10

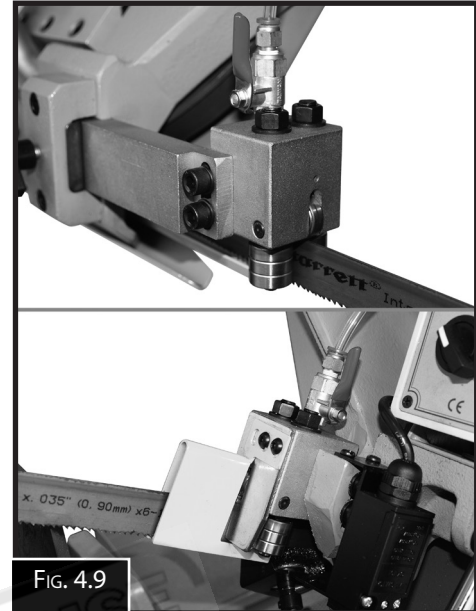

FIG. 4.9

4.4 SETTING THE DOWN FEED

The down feed is the speed at which the saw blade cuts through the workpiece. The rate at which the bow saw drops is controlled by a valve that can be adjusted to increase or decrease the speed that it moves.

To set the feed rate raise the bow to the highest position and hold it in place with the feed ON/OFF lever. (Fig. 4.11) Adjust the feed rate dial to the desired feed rate. Start the saw and coolant pump and begin cutting.

Examining the chips is the best indication of the correct blade speed and feed rate .

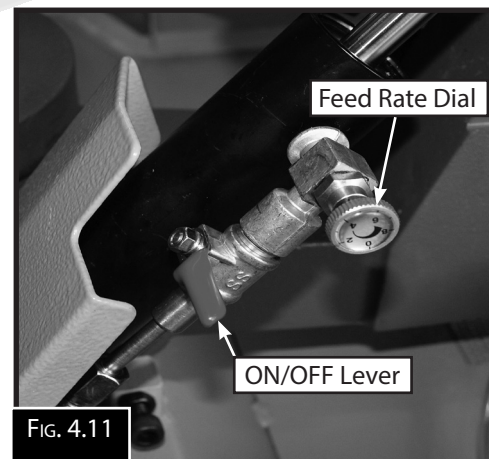
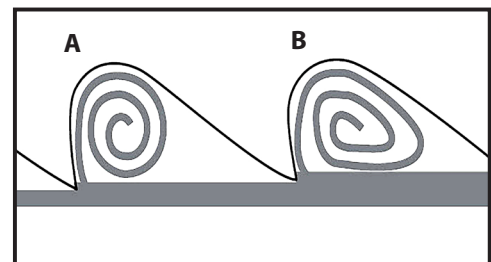

FIG. 4.11

- A.** This is the correct chip shape. The chip should be a silver colour. If the chips are blue then decrease the feed until they are silver. The shape also indicates that the blade TPI is correct.
- B.** This shape is in-correct. The shape is compressed and indicates that the chip is too big for the tooth gullet. This is the most common cause of broken teeth. Either decrease the feed or change to a larger TPI. blade.



4.5 SETTING THE CUTTING ANGLE

The band saw is fitted with the capacity to cut angles with the head being able to be swiveled up to 60° to the right. To set the angle of the cut, raise the bow saw to the highest point and hold by setting the ON/OFF lever to OFF.(Fig.4.11). Move the swivel lock lever (Fig.4.12) to the right and rotate the head until the scale (Fig.4.13) is at the angle required. Move the swivel lock lever to the left to lock the head. The machine is fitted with swivel a head stop at 60 degrees. (Fig.4.14)

NOTE: Please note that the scale (Fig.4.13) is for reference only and if the angle is required to be very accurate then the angle should be checked with a protractor after the cut.

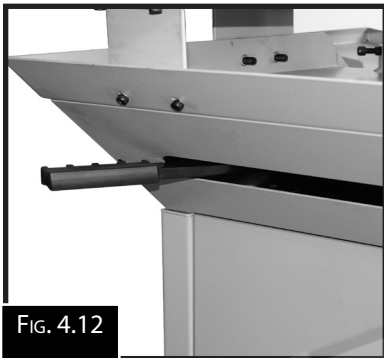

FIG. 4.12

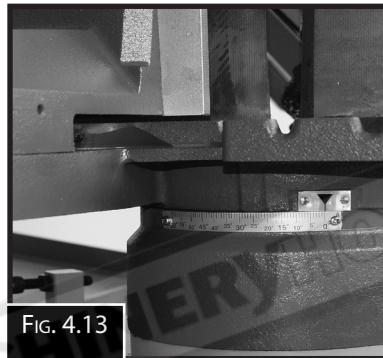

FIG. 4.13

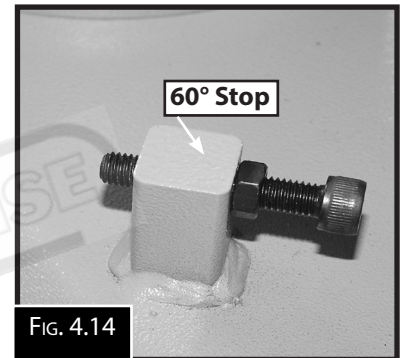

FIG. 4.14

To Swivel The Head To 60 Degrees

Move the swivel lock lever (Fig.4.12) to the right to release the head, then swivel the head until the pointer is on 60 . (Fig.4.15) The swivel head of the band saw will now be against the 60° stop (Fig.4.16) . Move the swivel lock to the left to lock the head.(Fig.4.12) To return to a right angle cut loosen the swivel lock and return the swivel head to the 0°with the head hard up against the stop.(Fig.4.17) Move swivel lock lever to the left to lock the head

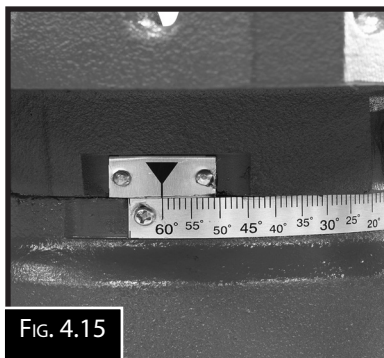

FIG. 4.15

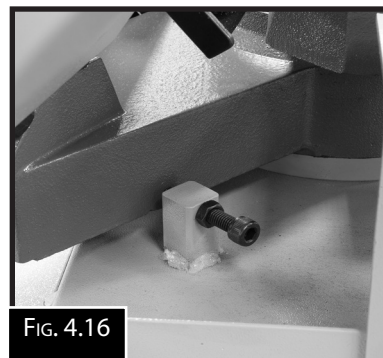

FIG. 4.16

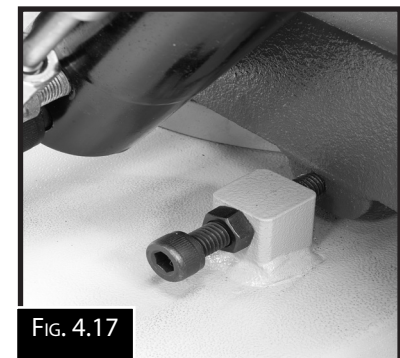

FIG. 4.17

4.6 ADJUSTING THE SPEED OF THE SAW BLADE

The HAFCO EB-260V is fitted with a variable speed motor which is controlled by the rotary dial on the control panel. (Fig.4.18) The speeds on the dial and in the table below are an estimate and should be varied to suit the application when the blade is running.

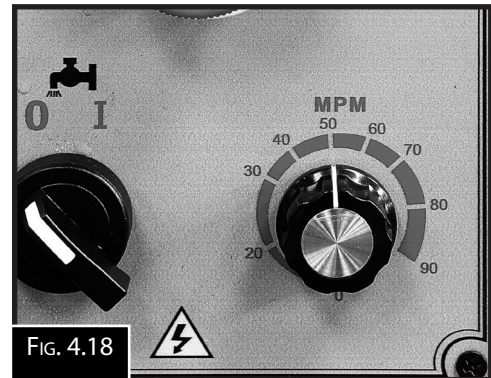

FIG. 4.18

Material	(m/mm)	Feed Motion per tooth(mm)	Material	(m/mm)	Feed Motion per tooth(mm)
C10, C15, ST34, ST37 Steel up to 500N/mm ²	30 ~ 50	0.03 ~ 0.06	Aluminium and Alloy Aluminium	600 ~ 900	0.04 ~ 0.09
C20, C40, 15Cr3 16MNC35 Steel up to 88 N/mm ²	20 ~ 40	0.03 ~ 0.04	Aluminium and Alloy Aluminium (Profiles)	800 ~ 1200	0.03 ~ 0.07
38NCD4, 50Cr3, 16MnC35 Steel up to 1200 N/mm ²	15 ~ 25	0.02 ~ 0.03	Brass and Copper	200 ~ 300	0.04 ~ 0.06
Stainless Steel	10 ~ 30	0.01 ~ 0.03	Bronze	400 ~ 600	0.04 ~ 0.08
Casting	30 ~ 50	0.04 ~ 0.05	Synthetic Materials	60 ~ 150	0.04 ~ 0.08

4.7 BUNDLE CUTTING.

HAFCO does not recommend that bundle cutting be done. See the chart as a guide (Fig. 4.19) to the quick position of the work piece between the vise jaws to avoid slipping during cutting.

Stacked or bundled steel can slip and cause the blade to break and may cause injury..

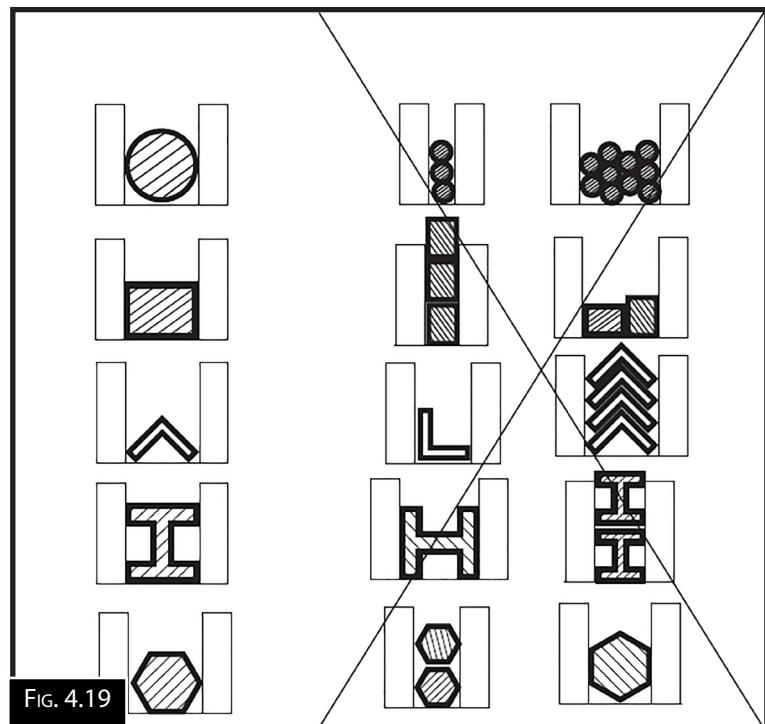

FIG. 4.19

OPERATION MANUAL

4.8 BLADE SELECTION

Band saw tooth size is determined by the size of the cross section to be cut. In general cutting thinner sections requires more teeth per inch, thicker sections require coarser pitches, or less teeth per inch. To select an appropriate tooth size please refer to the table immediately below unless material to be cut is a tube, in which case refer to the larger table below. For general purpose cutting use a constant pitch blade, for more aggressive production cutting of harder to cut materials use a variable pitch blade.

SOLID SECTION

Section Size (mm)	Constant Pitch (TPI)	Variable Pitch (TPI)
Up to 10	24 or 18	14/18 or 10/14
10 - 15	14	8 - 12
16 - 30	10	6 - 10
31 - 50	8	5 - 8
51 - 80	6	4 - 6
81 - 120	4	3 - 4
121 - 200	3	1 - 3
Over 200	2 or 1.25	1.4 - 2 or 0.8 - 1.3

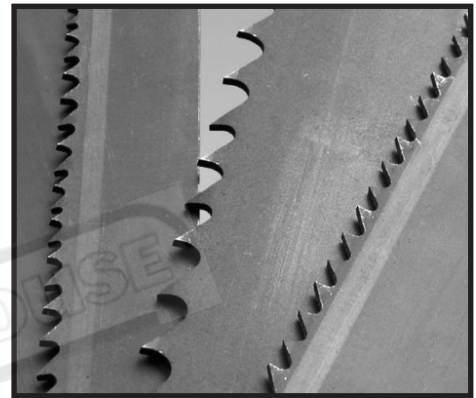

TUBE SECTION

Wall Thickness (mm)	Outside diameter of tube or maximum profile section length (mm)												
	20	40	60	80	100	120	150	200	300	500	600	700	800
2	14	14	14	14	14	14	10-14	10-14	8-12	8-12	6-10	5-8	5-8
3	14	14	10-14	10-14	10-14	10-14	8-12	8-12	6-10	6-10	5-8	5-8	5-8
4	14	14	10-14	10-14	8-12	8-12	6-10	6-10	5-8	5-8	4-6	4-6	4-6
5	14	10-14	10-14	8-12	8-12	6-10	6-10	5-8	5-8	4-6	4-6	4-6	4-6
6	14	10-14	10-14	8-12	8-12	6-10	6-10	5-8	5-8	4-6	4-6	3-4	3-4
8	16	10-14	8-12	8-12	6-10	6-10	5-8	5-8	4-6	4-6	3-4	3-4	3-4
10		8-12	8-12	6-10	6-10	5-8	5-8	4-6	4-6	3-4	3-4	3-4	3-4
12		8-12	6-10	6-10	5-8	5-8	4-6	4-6	3-4	3-4	3-4	3-4	2-3
15			6-10	5-8	5-8	4-6	4-6	4-6	3-4	3-4	3-4	2-3	2-3
20				5-8	4-6	4-6	4-6	3-4	3-4	2-3	2-3	2-3	2-3
30					4-6	4-6	3-4	3-4	3-4	2-3	2-3	2-3	2-3
50						3-4	3-4	3-4	2-3	2-3	2-3	2-3	2-3
75							2-3	2-3	2-3	2-3	2-3	1.4-2	1.4-2

5 MAINTENANCE

5.1 SCHEDULE

For the best performance of the machine follow the instructions given in this section and follow the schedule laid out below.

Daily Check

- Loose mounting bolts
- Damaged saw blade
- Correct blade tension
- Cutting fluid level
- Worn or damaged power lead
- Any unsafe condition

Monthly Check

- Lubricate vice screw
- Check cutting fluid levels

Annual Check

- Replace cutting fluids and clean out the tank.

5.2 CHANGING THE BLADE

The blade needs to be changed when it is dull or when teeth are missing. It also may need to be changed when the thickness of the material changes.

To change the blade.

1. DISCONNECT THE MACHINE FROM THE POWER SUPPLY.
2. Raise the bow saw for access and turn the feed ON/OFF lever to hold the bow saw up. (Fig. 5.1)
3. Remove the back cover by removing the 4 knobs displayed in Fig. 5.2.
4. Slide the upper blade guide as far as possible away from the lower blade guide.
5. Remove the blade guard on the movable roller guide by removing the two button head cap screws. (Fig.5.3)

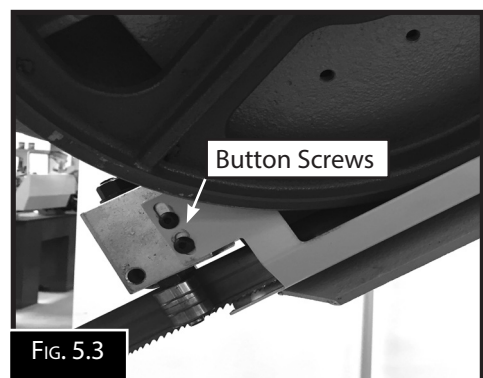
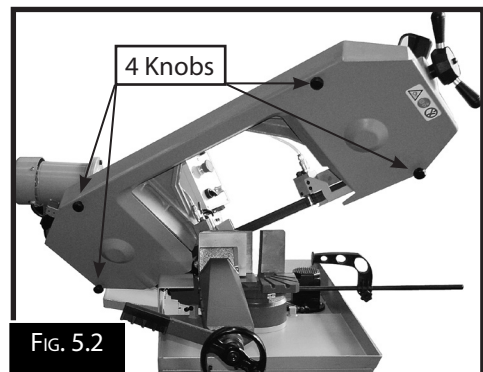
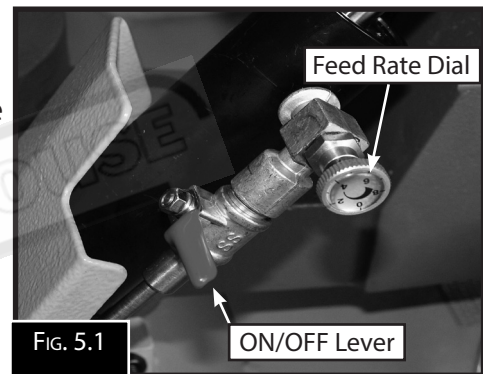

OPERATION MANUAL

6. Release the tension off the blade by turning the tension handle clockwise until the blade is loose. (Fig.5.4)
7. Remove the old blade and replace the new blade making sure that the teeth are facing in the right direction.

NOTE: Always wear leather gloves when handling cutting blades. The blades are very sharp and could cause injury to hands.

8. Re-tension the blade and replace the back cover.
9. Replace the blade guard on the movable roller guide making sure that the blade runs freely without touching the guards.
10. Adjust the movable blade guide so that it just clears the work piece.
11. Switch the machine on and make sure the blade is running correctly

FIG. 5.4

5.3 CHANGING THE COOLANT

This band saw is fitted with a coolant system that extends the life of the band saw blade by lowering the temperature of the blade and the workpiece.

To maintain the effectiveness of the cutting it is important to keep the coolant clean, therefore the coolant should be changed every 1000 hrs.

To change the coolant.

1. DISCONNECT THE MACHINE FROM THE POWER SUPPLY
2. Place a container under the drain and remove the drain plug on the side of the machine. (Fig 5.5)
3. Once the coolant is empty remove the two screws that secure the screen on the top of the reservoir, and remove the screen. (Fig.5.6)
4. With clean rags, wipe out the bottom of the coolant reservoir until it is clean and free from dirt or metal chips.
5. Replace the screen and drain plug and refill with clean coolant.

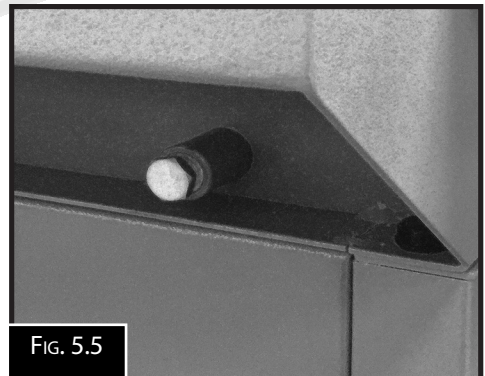
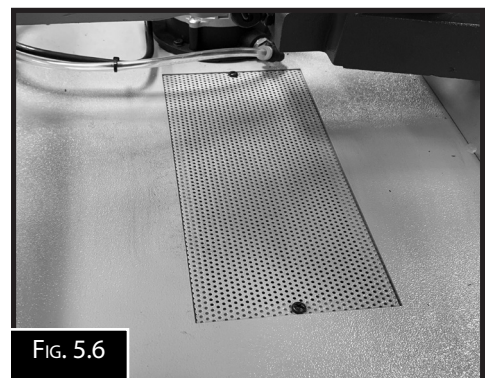
FIG. 5.5

FIG. 5.6

5.4 BLADE GUIDE ADJUSTMENT

The blade guides are set before the machine leaves the factory but may need to be adjusted due to movement while shipping, or general wear and tear after long operation.

To adjust the support roller

1. DISCONNECT THE BAND-SAW FROM THE POWER SUPPLY
2. Make sure that the blade is oiled and correctly tensioned.
3. Raise and lock the bow saw for easy access. Slide the blade guides as close as possible together and lock in place. Remove the blade guards by loosening the button head screws. (Fig.5.7)
4. Loosen the cap screws (Fig.5.8) and adjust the blade guide housing so the back of the blade just touches the bearing, making sure the guide housing is not tilted.
5. Tighten the cap screws.

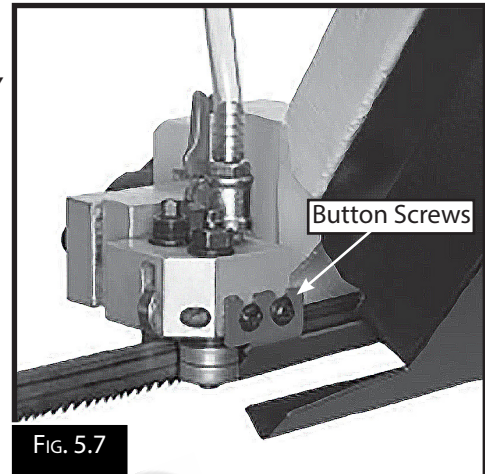

FIG. 5.7

NOTE: To access the cap screws on the other blade guide you will need to remove the two Phillips head screws and move the limit switch and its bracket out of the way.

To adjust the side bearings

1. Loosen the lock nut on the top of eccentric bolt.
2. Using a spanner on the hex section between the bearing and the casting, adjust the bearing, so it is against the side of the blade. There should be no clearance. (Fig. 5.9)
3. Tighten the lock nut making sure that the eccentric bolt does not turn.
4. Adjust the other ball bearing guide.
5. Repeat steps 1-4 on the other set of ball bearing guides on the opposite side of the saw bow.



FIG. 5.8

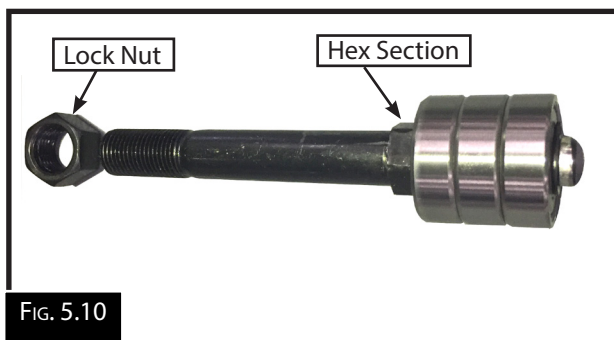

FIG. 5.10

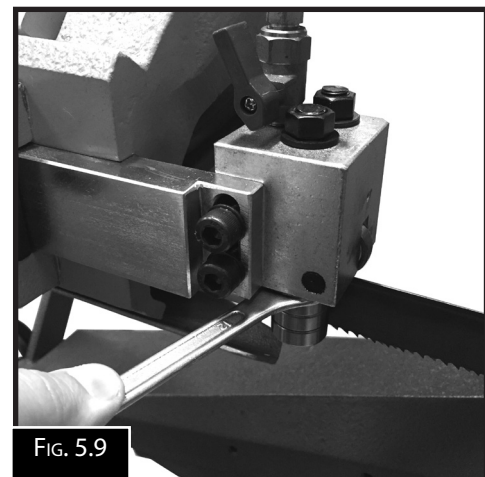

FIG. 5.9

5.5 ADJUSTING FEED STOPS

Before any blade adjustment is made it may be necessary to adjust the feed stop. The blade should never rest or rub on any part of the vice casting.

The over tilt stop may also need to be adjusted to stop the saw bow from being able to lift past 40° causing the machine to be unstable.

To Adjust the Feed Stop Bolt

1. Disconnect the machine from the power supply
2. Release the lock nut on the Feed Stop bolt.(Fig.5.11)
3. Adjust the feed bolt until the teeth on the saw blade are just below the vise table surface when the machine stops.
4. Tighten the lock nut and run the machine cycle and check that the adjustment is correct.

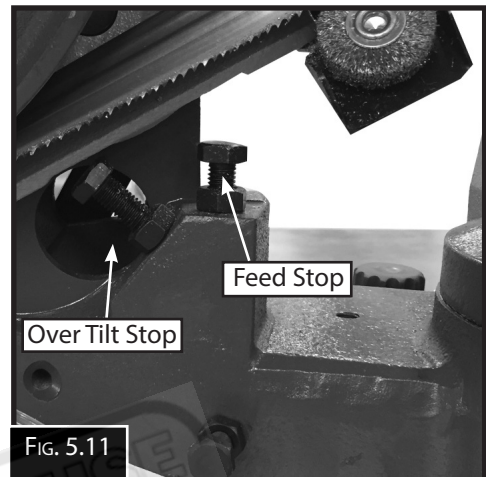

FIG. 5.11

5.6 ADJUSTING THE FEED AUTO STOP

During adjustment of the blade guides it may be necessary to remove the feed auto stop for better access. If this has happened then the feed auto stop needs to be reset.

To adjust the feed auto stop.

Undo the lock nut on the feed auto stop bolt and adjust the bolt so that the teeth on the band-saw blade are just below the vice table surface when the blade has finished the cut and the machine stops.(Fig.5.12)

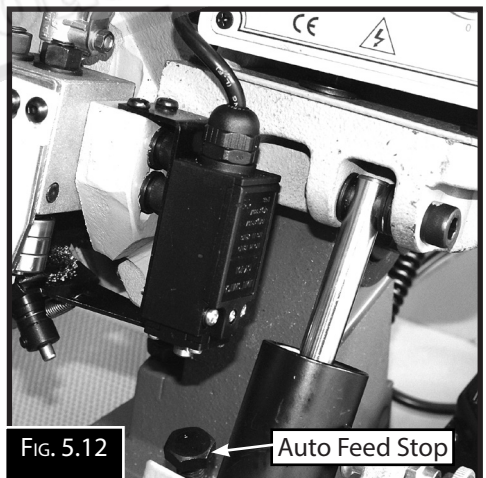

FIG. 5.12

5.7 ADJUSTING THE HEAD SWIVEL STOPS

The head swivel stops are set by the factory, but due to shipping or continuing use, the stops may need to be adjusted.

NOTE: The scale is only to be used for approximate guide. For accurate setting a protractor should be used

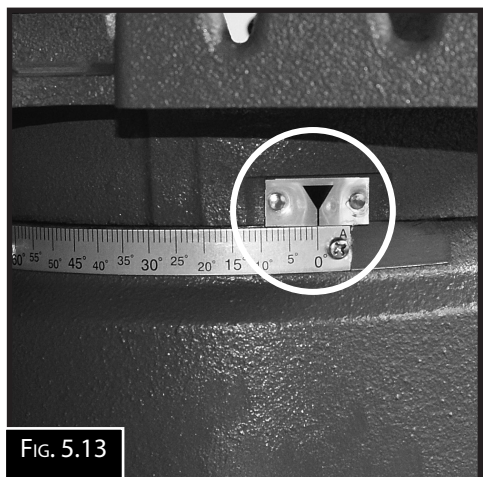

FIG. 5.13

To adjust the Zero (90°) stop.

1. DISCONNECT THE BAND SAW FROM THE POWER SUPPLY
2. Make sure that the blade is oiled and tensioned, tracking correctly, and the guides are set correctly
3. Raise the saw bow, then move the head and set the scale to "0". (Fig. 5.13) then lower the saw bow and lock in place.
4. Check that the "0" head stop is hard up against the stop. If there is a gap between the pad (Fig. 5.14) and the stop screw, then loosen the lock nut and adjust the stop bolt until it rests against the pad.
5. Tighten the lock nut on the swivel head bolt.
6. Unlock the head and swivel the head away from the stop and the return and check that the adjustment is correct.

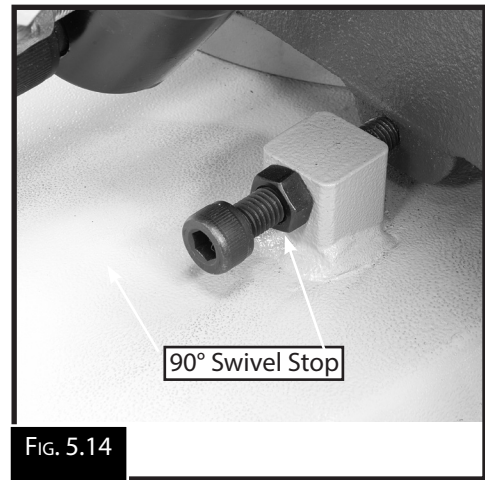

FIG. 5.14

To adjust the 60° angle stops.

1. DISCONNECT THE BAND SAW FROM THE POWER SUPPLY
2. Make sure that the blade is oiled and tensioned, tracking correctly, and the guides are set correctly
3. Raise the saw bow, then move the head and set the scale to 60°. (Fig. 5.15) then lower the saw bow and lock in place.
4. Check that the 60° head stop is hard up against the casting. If there is a gap between the casting (Fig. 5.16) and the stop screw, then loosen the lock nut and adjust the stop bolt until it rests against the casting.
5. Tighten the lock nut on the swivel head bolt.
6. Unlock the head and swivel the head away from the stop and the return and check that the adjustment is correct
7. Raise the saw bow and swivel the head until it reaches the 60° stop. Check the scale to see if the pointer is on 60°. If the head did not completely reach the 60° or it has over shot the mark then adjust the stop as in Steps 4-6 until it lines up with the scale.

NOTE: The scale is used only as a guide. Cuts should be checked with a protractor.

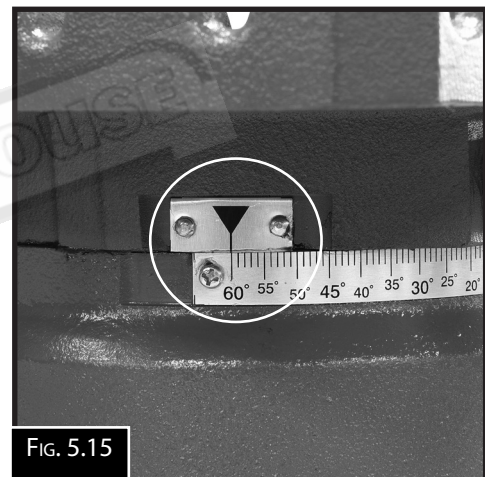

FIG. 5.15

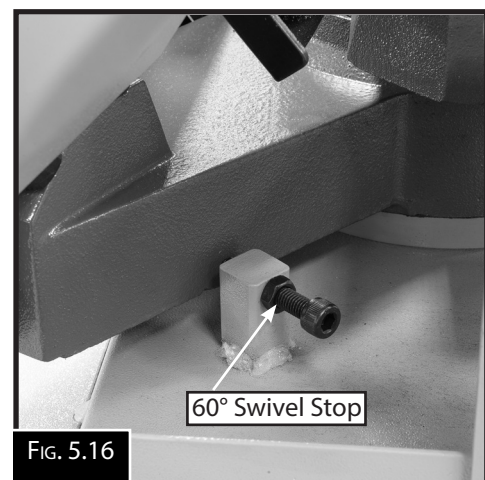

FIG. 5.16

OPERATION MANUAL

5.3 TROUBLE SHOOTING

If the machine develops a problem, review the trouble shooting section below to find a fix for the problem. If the problem cannot be solved then contact your dealer for help or to book a service engineer.

SYMPTOM	POSSIBLE CAUSE	ACTION REQUIRED
Machine does not start	<ol style="list-style-type: none"> 1. Emergency Stop button pressed 2. Power Supply in the OFF position 3. Motor ON/OFF switch is faulty 4. Faulty Motor 	<ol style="list-style-type: none"> 1. Reset the E-Stop by twisting the button 2. Check power supply is ON and not faulty 3. Test and replace the switch 4. Test and replace the motor.
Machine stalls or seems underpowered	<ol style="list-style-type: none"> 1. Wrong blade for the work piece 2. Feed rate too fast for the blade 3. Blade is slipping on the wheels 4. Motor over heating 5. Motor is faulty 	<ol style="list-style-type: none"> 1. Change to the correct blade 2. Decrease the feed rate 3. Adjust the blade guides and the tension 4. Let the motor cool and reduce the work load 5. Test and replace
Machine is noisy or vibrates	<ol style="list-style-type: none"> 1. Blade is faulty 2. Motor fan is rubbing on cover 3. Speed is set too slow 	<ol style="list-style-type: none"> 1. Replace with new or correct blade 2. Adjust and tighten fan or replace 3. Adjust the speed to suit the work piece
Machine bogs down or is loud	<ol style="list-style-type: none"> 1. Excessive feed rate 2. The blade T.P.I. is too great for the material 	<ol style="list-style-type: none"> 1. Reduce the feed rate 2. Check for the correct blade (Page 16)
Blades Breaking	<ol style="list-style-type: none"> 1. Blade is not tension correctly 2. Loose work piece 3. The feed or cutting speed is wrong 4. Incorrect blade selection 5. The blade is too thick or low quality 	<ol style="list-style-type: none"> 1. Check the blade tension (Page 13) 2. Re-clamp the work piece tighter or use a jig 3. Adjust the feed rate and the speed (Page 14) 4. Refer to blade selection (Page 16) 5. Use better quality blade
Teeth breaking of the blade	<ol style="list-style-type: none"> 1. The feed is too great 2. The blade T.P.I. is too coarse 3. Blade gullets are loaded up with chips 	<ol style="list-style-type: none"> 1. Decrease the blade pressure 2. Refer to blade selection (Page 16) 3. Use a coarser tooth blade
The cuts are crooked	<ol style="list-style-type: none"> 1. The feed pressure is too high 2. The blade tension is low 3. The blade is dull 	<ol style="list-style-type: none"> 1. Reduce the feed rate 2. Adjust the blade tension as required. 3. Replace the blade.

TROUBLE SHOOTING Cont.

SAW BLADE DOES NOT CUT SQUARE.

Check to see if the saw blade is cutting square. If the blade is not cutting square as per the example (Fig. 5.17)

1. Replace with a new blade and check for squareness. The workpiece should be as per Fig. 5.18
2. Inspect the blade guides to see if there is a gap between the bearings and the blade (Fig.5.19)

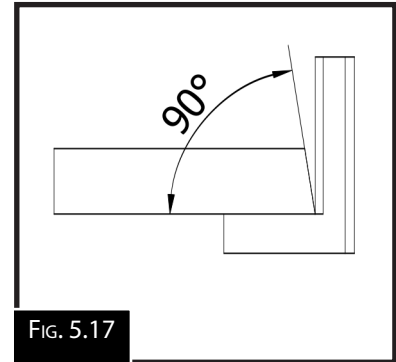

FIG. 5.17

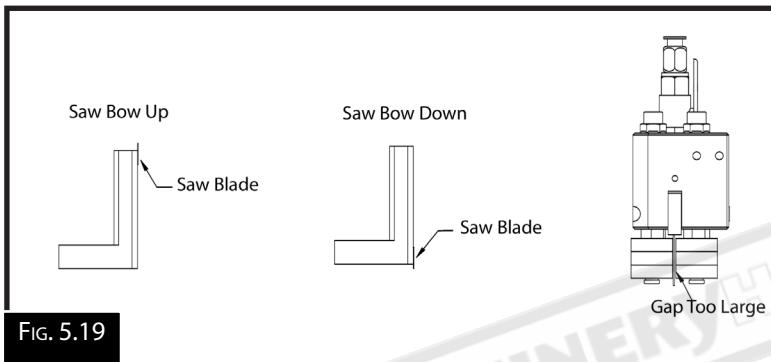

FIG. 5.19

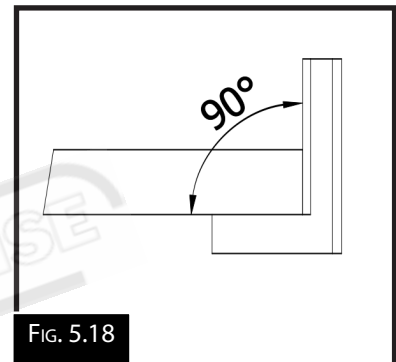

FIG. 5.18

SPARE PARTS SECTION

The following section covers the spare parts diagrams and lists that were current at the time this manual was originally printed. Due to continuous improvements of the machine, changes may be made at any time without notification.

HOW TO ORDER SPARE PARTS

1. Have your machines **model number, serial number & date of manufacture** on hand, these can be found on the specification plate mounted on the machine
2. A scanned copy of your parts list/diagram with required spare part/s identified
3. Go to www.machineryhouse.com.au/contactus and fill out the inquiry form attaching a copy of scanned parts list.



OPERATION MANUAL

SPARE PARTS DIAGRAM

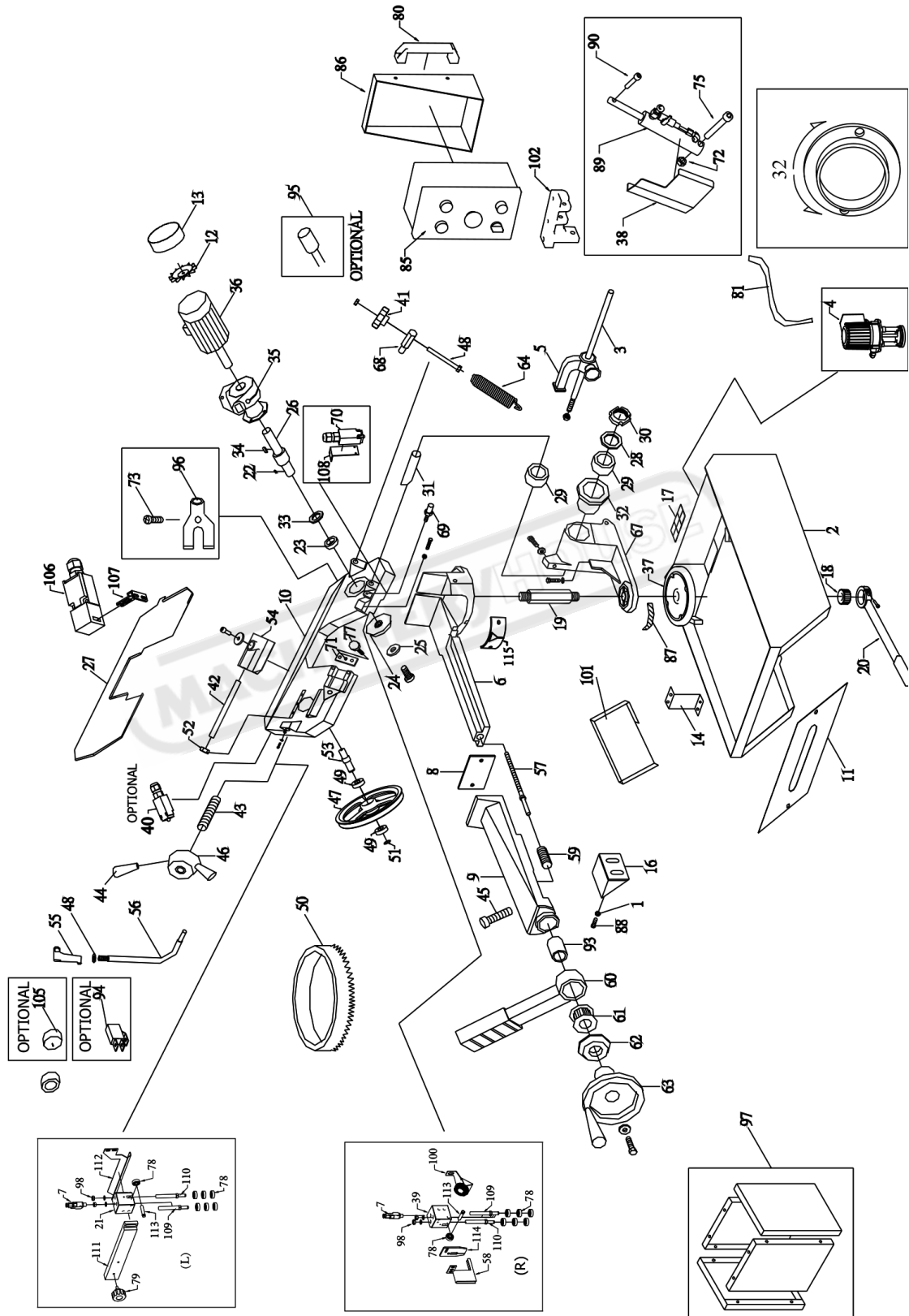

OPERATION MANUAL

EB-260V SPARE PARTS LIST

Ref. No.	Description	Ref. No.	Description	Ref. No.	Description
01	Washer	51	C-ring C	101	Plate
02	Base	52	Hex, Nuts.	102	Bracket
03	Bar Stop Rod	53	Blade Steel Shaft		
04	Coolant Pump	54	Block Blade Tension	104	Pivots Eccentric
05	Bar Stop	55	Handle	105	Blade Tension Gauge (optional)
06	Counter-vice	56	Lever	106	Switch
07	Valve	57	Vice Screw	107	Key
08	Vice Jaw	58	R. Blade-guard	108	Block
09	Vice	59	Vice Spring	109	Pivots Centric
10	Body Frame	60	Vice lever	110	Pivots Eccentric
11	Casing	61	Bearing	111	Arm
12	Motor Fan	62	Bearing Cover	112	Blade Guard
13	Motor Cover	63	Vice Hand Wheel	113	Pin
14	Connection Plate	64	Spring	114	Rust Plate
16	Arm	65	Spring Connection	115	Scale
17	Filter	67	Revolving Arm		
18	Bush	68	Rod		
19	Pin	69	Stop Bolt		
20	Lever	70	Micro Switch (optional)		
21	Fixed Blade Guide Plate	71	Block		
22	Key 7x7x35mm	72	Hex. Nuts		
23	Bearing	73	Rubber Connection		
24	Motor Flywheel	74	Arm		
25	Washer	75	Bolt		
26	Shaft	76	Blade Guard		
27	Blade Cover	77	Handle		
28	Ring Nylon	78	Bearing 6082Z 608		
29	Bearing 32006	79	Hand Wheel		
30	Ring Nut M30	80	Handle		
31	Pivot	81	Water Pipe		
32	Bearing Cover	82	Rust Plate		
33	Washer	83	L. Blade-guard		
34	Key 8 x 7 x 25 mm	84	Switch Set		
35	Reducer	85	Brush (optional)		
36	Motor	86	Switch Shaft		
37	Round Table	87	Scale		
38	Plate (optional)	89	Cylinder (optional)		
39	Mobile Blade Guide Plate	90	Pin (optional)		
40	Switch (optional)	91	Fixed Blade Guide Plate		
41	Hand Wheel	92	Mobile Blade Guide Plate		
42	Threaded Shaft	93	Bush		
43	Spring Washer	94	Toggle Switch		
44	Grip	95	Condenser (Motor) (optional)		
45	Pin				
46	Hand Wheel	96	Coolant Distributor		
47	Return Flywheel	97	Stand		
48	Hex. Nut	98	Nut M10		
49	Bearings 2Z/6205 6205	99	Pivots Centric		
50	Saw Blade	100	Brush		



OPERATION MANUAL

EB-260V ELECTRICAL DIAGRAM

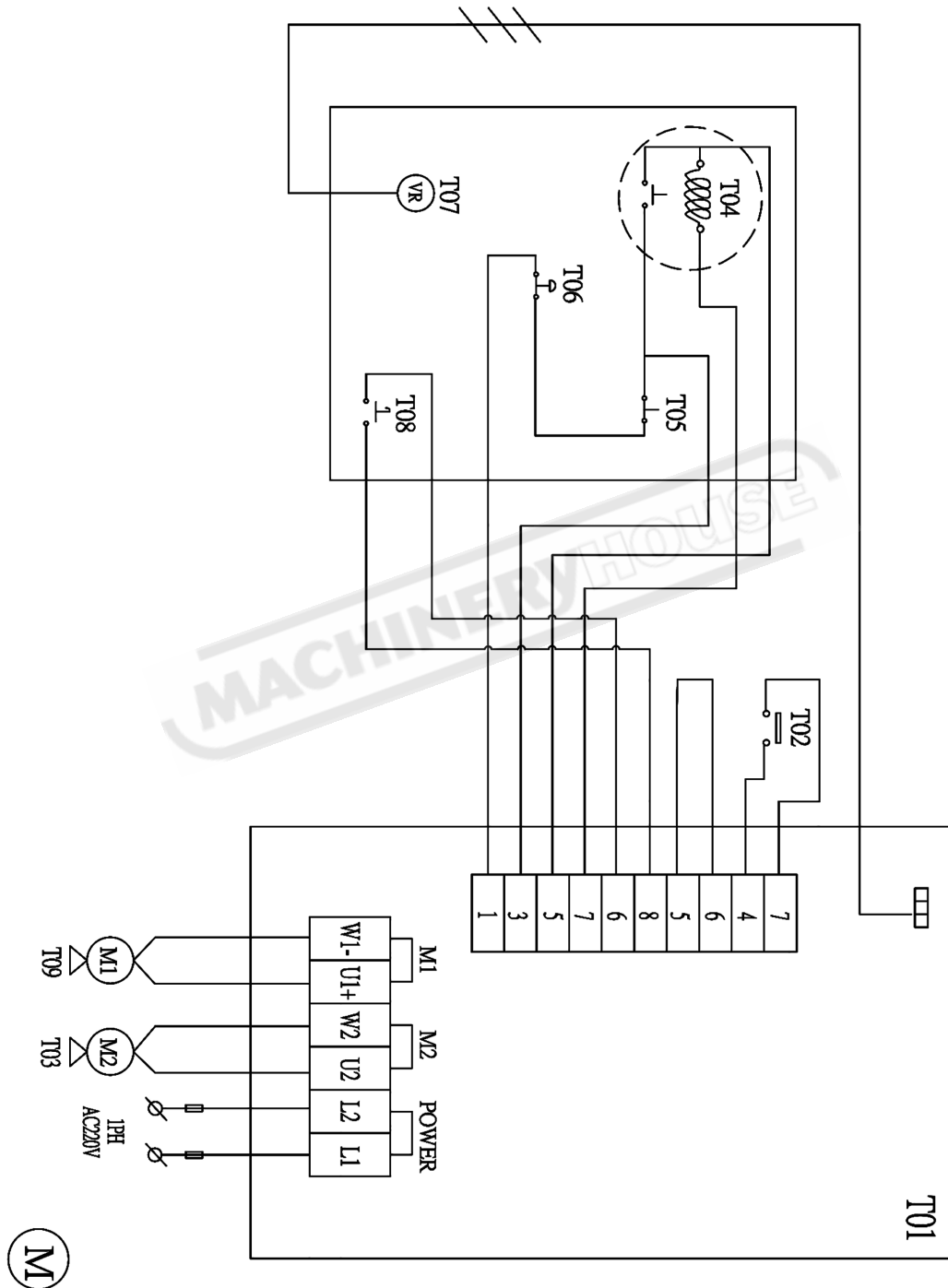



OPERATION MANUAL

EB-260V ELECTRICAL PARTS LISTS

Part No.	Name	Description	Manufacturer	Mark
T01	PCB	CY-815DVP	George	CE
T02	Safe Micro	Micro Switch	Haily	CE
T03	M2	Pump Motor	George	CE
T04	ON	I Switch	Tend	CE
T05	OFF	O Switch	Tend	CE
T06	EMS	Emergency Stop	Demex	CE
T07	VR	Converter VR	George	CE
T08	Coolant	Pump Switch	Tend	CE
T09	M1	Main Motor	George	CE



WARNING

General Machinery Safety Instructions

Machinery House
requires you to read this entire Manual before using this machine.

- 1. Read the entire Manual before starting machinery.** Machinery may cause serious injury if not correctly used.
- 2. Always use correct hearing protection when operating machinery.** Machinery noise may cause permanent hearing damage.
- 3. Machinery must never be used when tired, or under the influence of drugs or alcohol.** When running machinery you must be alert at all times.
- 4. Wear correct Clothing.** At all times remove all loose clothing, necklaces, rings, jewelry, etc. Long hair must be contained in a hair net. Non-slip protective footwear must be worn.
- 5. Always wear correct respirators around fumes or dust when operating machinery.** Machinery fumes & dust can cause serious respiratory illness. Dust extractors must be used where applicable.
- 6. Always wear correct safety glasses.** When machining you must use the correct eye protection to prevent injuring your eyes.
- 7. Keep work clean and make sure you have good lighting.** Cluttered and dark shadows may cause accidents.
- 8. Personnel must be properly trained or well supervised when operating machinery.** Make sure you have clear and safe understanding of the machine you are operating.
- 9. Keep children and visitors away.** Make sure children and visitors are at a safe distance for you work area.
- 10. Keep your workshop childproof.** Use padlocks, Turn off master power switches and remove start switch keys.
- 11. Never leave machine unattended.** Turn power off and wait till machine has come to a complete stop before leaving the machine unattended.
- 12. Make a safe working environment.** Do not use machine in a damp, wet area, or where flammable or noxious fumes may exist.
- 13. Disconnect main power before service machine.** Make sure power switch is in the off position before re-connecting.
- 14. Use correct amperage extension cords.** Undersized extension cords overheat and lose power. Replace extension cords if they become damaged.
- 15. Keep machine well maintained.** Keep blades sharp and clean for best and safest performance. Follow instructions when lubricating and changing accessories.
- 16. Keep machine well guarded.** Make sure guards on machine are in place and are all working correctly.
- 17. Do not overreach.** Keep proper footing and balance at all times.
- 18. Secure workpiece.** Use clamps or a vice to hold the workpiece where practical. Keeping the workpiece secure will free up your hand to operate the machine and will protect hand from injury.
- 19. Check machine over before operating.** Check machine for damaged parts, loose bolts, Keys and wrenches left on machine and any other conditions that may effect the machines operation. Repair and replace damaged parts.
- 20. Use recommended accessories.** Refer to instruction manual or ask correct service officer when using accessories. The use of improper accessories may cause the risk of injury.
- 21. Do not force machinery.** Work at the speed and capacity at which the machine or accessory was designed.
- 22. Use correct lifting practice.** Always use the correct lifting methods when using machinery. Incorrect lifting methods can cause serious injury.
- 23. Lock mobile bases.** Make sure any mobile bases are locked before using machine.
- 24. Allergic reactions.** Certain metal shavings and cutting fluids may cause an allergic reaction in people and animals, especially when cutting as the fumes can be inhaled. Make sure you know what type of metal and cutting fluid you will be exposed to and how to avoid contamination.
- 25. Call for help.** If at any time you experience difficulties, stop the machine and call you nearest branch service department for help.



Metal Cutting Bandsaw Safety Instructions

Machinery House
requires you to read this entire Manual before using this machine.

- 1. Maintenance.** Make sure the bandsaw is turned off and disconnect from the main power supply and make sure all moving parts have come to a complete stop before any inspection, adjustment or maintenance is carried out.
- 2. Bandsaw Condition.** Bandsaw must be maintained for a proper working condition. Never operate a bandsaw that has damaged or worn parts. Scheduled routine maintenance should be performed on a scheduled basis.
- 3. Blade Condition.** Never operate a bandsaw with a dull, cracked or badly worn blade. Before using a bandsaw inspect blades for missing teeth and cracks.
- 4. Replacing Blade.** Make sure teeth are facing the correct direction. Wear gloves to protect hands and wear safety glasses to protect your eyes.
- 5. Hand Hazard.** Keep hands and fingers clear from the line of cut of the blade and offcuts workpieces. Hands can be crushed in vice or from falling machine components and cut by the blade.
- 6. Leaving a bandsaw Unattended.** Always turn the bandsaw off and make sure all moving parts have come to a complete stop before leaving the bandsaw. Do not leave bandsaw running unattended for any reason.
- 7. Avoiding Entanglement.** Blade guard must be used at all times. Remove loose clothing, belts, or jewelry items. Never wear gloves while machine is in operation. Tie up long hair and use the correct hair nets to avoid any entanglement with the bandsaw moving parts.
- 8. Understand the machines controls.** Make sure you understand the use and operation of all controls.
- 9. Power outage.** In the event of a power failure during use of the bandsaw, turn off all switches to avoid possible sudden start up once power is restored.
- 10. Work area hazards.** Keep the area around the bandsaw clean from oil, tools, chips. Pay attention to other persons in the area and know what is going on around the area to ensure unintended accidents.
- 11. Workpiece Handling.** Workpieces must be supported with table, vice, roller conveyor/stands, or other support fixtures. Unsupported workpieces may cause the machine to tip over and fall. Flag long pieces of material to avoid tripping hazards. Never hold a workpiece with your hands during the cut process.
- 12. Hearing protection and hazards.** Always wear hearing protection as noise generated from bandsaw blade and workpiece vibration, material handling, and power transmission can cause permanent hearing loss over time.
- 13. Hot surfaces.** Workpieces, machine surfaces and chips become hot due to friction and can burn you.
- 14. Starting position.** Never turn the bandsaw on when the blade is resting on the workpiece.
- 15. Guards.** Do not operate bandsaw without the blade guard in place or with the doors open. Ensure all guards removed to do maintenance or change blades on the machine are refitted correctly in place before the machine is used again.
- 16. Call for help.** If at any time you experience difficulties, stop the machine and call your nearest branch service department for help.

PLANT SAFETY PROGRAM

NEW MACHINERY HAZARD IDENTIFICATION, ASSESSMENT & CONTROL

Metal Cutting Bandsaw

Developed in Co-operation Between A.W.I.S.A and Australia Chamber of Manufactures
This program is based upon the Safe Work Australia, Code of Practice - Managing Risks of Plant in the Workplace (WHSA 2011 No10)

Item No.	Hazard Identification	Hazard Assessment	Risk Control Strategies <small>(Recommended for Purchase / Buyer / User)</small>
A	ENTANGLEMENT	HIGH	Eliminate, avoid loose clothing / Long hair etc.
B	CRUSHING	LOW	Secure & support Long / heavy material
C	CUTTING, STABBING, PUNCTURING	MEDIUM	Blade guards should always be in the closed position before starting machine. Blade guide system should be adjusted to suit material width. Wear gloves when changing blades. Isolate main power switch before changing blade, cleaning or adjusting. If blade breaks do not open door until both wheels have stopped. Check blade tracking before starting.
D	SHEARING	MEDIUM	Make sure all guards are secured shut when machine is on. Isolate power to machine prior to changing belts or maintenance.
F	STRIKING	LOW	Support long heavy jobs and stand clear of offcuts. Stand clear of machine when in operation. Remove all loose objects around moving parts. Wear safety glasses
H	ELECTRICAL	MEDIUM	All electrical enclosures should only be opened with a tool that is not to be kept with the machine. Machine should be installed & checked by a Licensed Electrician.
O	OTHER HAZARDS, NOISE.	LOW	Wear hearing protection as required.
Plant Safety Program to be read in conjunction with manufactures instructions			



www.machineryhouse.com.au



www.machineryhouse.co.nz

Authorised and signed by:
Safety officer:



Manager:



Revised Date: 12th March 2012